

Fiber Optic Connectors and Accessories

FPM 101 / FLS 101

Fiber Optic Test Set



Extron® Electronics
INTERFACING, SWITCHING AND CONTROL

Safety Instructions • English



This symbol is intended to alert the user of important operating and maintenance (servicing) instructions in the literature provided with the equipment.



This symbol is intended to alert the user of the presence of uninsulated dangerous voltage within the product's enclosure that may present a risk of electric shock.

Caution

Read Instructions • Read and understand all safety and operating instructions before using the equipment.

Retain Instructions • The safety instructions should be kept for future reference.

Follow Warnings • Follow all warnings and instructions marked on the equipment or in the user information.

Avoid Attachments • Do not use tools or attachments that are not recommended by the equipment manufacturer because they may be hazardous.

Consignes de Sécurité • Français



Ce symbole sert à avertir l'utilisateur que la documentation fournie avec le matériel contient des instructions importantes concernant l'exploitation et la maintenance (réparation).



Ce symbole sert à avertir l'utilisateur de la présence dans le boîtier de l'appareil de tensions dangereuses non isolées posant des risques d'électrocution.

Attention

Lire les instructions • Prendre connaissance de toutes les consignes de sécurité et d'exploitation avant d'utiliser le matériel.

Conservier les instructions • Ranger les consignes de sécurité afin de pouvoir les consulter à l'avenir.

Respecter les avertissements • Observer tous les avertissements et consignes marqués sur le matériel ou présentés dans la documentation utilisateur.

Éviter les pièces de fixation • Ne pas utiliser de pièces de fixation ni d'outils non recommandés par le fabricant du matériel car cela risquerait de poser certains dangers.

Sicherheitsanleitungen • Deutsch



Dieses Symbol soll dem Benutzer in der im Lieferumfang enthaltenen Dokumentation besonders wichtige Hinweise zur Bedienung und Wartung (Instandhaltung) geben.



Dieses Symbol soll den Benutzer darauf aufmerksam machen, daß im Inneren des Gehäuses dieses Produktes gefährliche Spannungen, die nicht isoliert sind und die einen elektrischen Schock verursachen können, herrschen.

Achtung

Lesen der Anleitungen • Bevor Sie das Gerät zum ersten Mal verwenden, sollten Sie alle Sicherheits- und Bedienungsanleitungen genau durchlesen und verstehen.

Aufbewahren der Anleitungen • Die Hinweise zur elektrischen Sicherheit des Produktes sollten Sie aufbewahren, damit Sie im Bedarfsfall darauf zurückgreifen können.

Befolgen der Warnhinweise • Befolgen Sie alle Warnhinweise und Anleitungen auf dem Gerät oder in der Benutzerdokumentation.

Keine Zusatzgeräte • Verwenden Sie keine Werkzeuge oder Zusatzgeräte, die nicht ausdrücklich vom Hersteller empfohlen wurden, da diese eine Gefahrenquelle darstellen können.

Instrucciones de seguridad • Español



Este símbolo se utiliza para advertir al usuario sobre instrucciones importantes de operación y mantenimiento (o cambio de partes) que se desean destacar en el contenido de la documentación suministrada con los equipos.



Este símbolo se utiliza para advertir al usuario sobre la presencia de elementos con voltaje peligroso sin protección aislante, que puedan encontrarse dentro de la caja o alojamiento del producto, y que puedan representar riesgo de electrocución.

Precaución

Leer las instrucciones • Leer y analizar todas las instrucciones de operación y seguridad, antes de usar el equipo.

Conservar las instrucciones • Conservar las instrucciones de seguridad para futura consulta.

Obedecer las advertencias • Todas las advertencias e instrucciones marcadas en el equipo o en la documentación del usuario, deben ser obedecidas.

Evitar el uso de accesorios • No usar herramientas o accesorios que no sean específicamente recomendados por el fabricante, ya que podrían implicar riesgos.

安全须知 • 中文



这个符号提示用户该设备用户手册中有重要的操作和维护说明。



这个符号警告用户该设备机壳内有暴露的危险电压，有触电危险。

注意

阅读说明书 • 用户使用该设备前必须阅读并理解所有安全和使用说明。

保存说明书 • 用户应保存安全说明书以备将来使用。

遵守警告 • 用户应遵守产品和用户指南上的所有安全和操作说明。

避免追加 • 不要使用该产品厂商没有推荐的工具或追加设备，以避免危险。

Warning

Power sources • This equipment should be operated only from the power source indicated on the product. This equipment is intended to be used with a main power system with a grounded (neutral) conductor. The third (grounding) pin is a safety feature, do not attempt to bypass or disable it.

Power disconnection • To remove power from the equipment safely, remove all power cords from the rear of the equipment, or the desktop power module (if detachable), or from the power source receptacle (wall plug).

Power cord protection • Power cords should be routed so that they are not likely to be stepped on or pinched by items placed upon or against them.

Servicing • Refer all servicing to qualified service personnel. There are no user-serviceable parts inside. To prevent the risk of shock, do not attempt to service this equipment yourself because opening or removing covers may expose you to dangerous voltage or other hazards.

Slots and openings • If the equipment has slots or holes in the enclosure, these are provided to prevent overheating of sensitive components inside. These openings must never be blocked by other objects.

Lithium battery • There is a danger of explosion if battery is incorrectly replaced. Replace it only with the same or equivalent type recommended by the manufacturer. Dispose of used batteries according to the manufacturer's instructions.

Avertissement

Alimentations • Ne faire fonctionner ce matériel qu'avec la source d'alimentation indiquée sur l'appareil. Ce matériel doit être utilisé avec une alimentation principale comportant un fil de terre (neutre). Le troisième contact (de mise à la terre) constitue un dispositif de sécurité : n'essayez pas de la contourner ni de la désactiver.

Déconnexion de l'alimentation • Pour mettre le matériel hors tension sans danger, déconnectez tous les cordons d'alimentation de l'arrière de l'appareil ou du module d'alimentation de bureau (s'il est amovible) ou encore de la prise secteur.

Protection du cordon d'alimentation • Acheminer les cordons d'alimentation de manière à ce que personne ne risque de marcher dessus et à ce qu'ils ne soient pas écrasés ou pincés par des objets.

Réparation-maintenance • Faire exécuter toutes les interventions de réparation-maintenance par un technicien qualifié. Aucun des éléments internes ne peut être réparé par l'utilisateur. Afin d'éviter tout danger d'électrocution, l'utilisateur ne doit pas essayer de procéder lui-même à ces opérations car l'ouverture ou le retrait des couvercles risquent de l'exposer à de hautes tensions et autres dangers.

Fentes et orifices • Si le boîtier de l'appareil comporte des fentes ou des orifices, ceux-ci servent à empêcher les composants internes sensibles de surchauffer. Ces ouvertures ne doivent jamais être bloquées par des objets.

Lithium Batterie • Il y a danger d'explosion s'il y a un remplacement incorrect de la batterie. Remplacer uniquement avec une batterie du même type ou d'un type équivalent recommandé par le constructeur. Mettre au rebut les batteries usagées conformément aux instructions du fabricant.

Vorsicht

Stromquellen • Dieses Gerät sollte nur über die auf dem Produkt angegebene Stromquelle betrieben werden.

Dieses Gerät wurde für eine Verwendung mit einer Hauptstromleitung mit einem geerdeten (neutralen) Leiter konzipiert. Der dritte Kontakt ist für einen Erdschluß, und stellt eine Sicherheitsfunktion dar. Diese sollte niemals umgangen oder außer Betrieb gesetzt werden.

Stromunterbrechung • Um das Gerät auf sichere Weise vom Netz zu trennen, sollten Sie alle Netzkabel aus der Rückseite des Gerätes, aus der externen Stromversorgung (falls dies möglich ist) oder aus der Wandsteckdose ziehen.

Schutz des Netzkabels • Netzkabel sollten stets so verlegt werden, daß sie nicht im Weg liegen und niemand darauf treten kann oder Objekte darauf- oder unmittelbar dagegengestellt werden können.

Wartung • Alle Wartungsmaßnahmen sollten nur von qualifiziertem Servicepersonal durchgeführt werden. Die internen Komponenten des Gerätes sind wartungsfrei. Zur Vermeidung eines elektrischen Schocks versuchen Sie in keinem Fall, dieses Gerät selbst öffnen, da beim Entfernen der Abdeckungen die Gefahr eines elektrischen Schlags und/oder andere Gefahren bestehen.

Schlitze und Öffnungen • Wenn das Gerät Schlitze oder Löcher im Gehäuse aufweist, dienen diese zur Vermeidung einer Überhitzung der empfindlichen Teile im Inneren. Diese Öffnungen dürfen niemals von anderen Objekten blockiert werden.

Lithium-Batterie • Explosionsgefahr, falls die Batterie nicht richtig ersetzt wird. Ersetzen Sie verbrauchte Batterien nur durch den gleichen oder einen vergleichbaren Batterietyp, der auch vom Hersteller empfohlen wird. Entsorgen Sie verbrauchte Batterien bitte gemäß den Herstelleranweisungen.

Advertencia

Alimentación eléctrica • Este equipo debe conectarse únicamente a la fuente/tipo de alimentación eléctrica indicada en el mismo. La alimentación eléctrica de este equipo debe provenir de un sistema de distribución general con conductor neutro a tierra. La tercera pata (puesta a tierra) es una medida de seguridad, no puentearla ni eliminarla.

Desconexión de alimentación eléctrica • Para desconectar con seguridad la acometida de alimentación eléctrica al equipo, desenchufar todos los cables de alimentación en el panel trasero del equipo, o desenchufar el módulo de alimentación (si fuera independiente), o desenchufar el cable del receptáculo de la pared.

Protección del cables de alimentación • Los cables de alimentación eléctrica se deben instalar en lugares donde no sean pisados ni apretados por objetos que se puedan apoyar sobre ellos.

Reparaciones/mantenimiento • Solicitar siempre los servicios técnicos de personal calificado. En el interior no hay partes a las que el usuario deba acceder. Para evitar riesgo de electrocución, no intentar personalmente la reparación/mantenimiento de este equipo, ya que al abrir o extraer las tapas puede quedar expuesto a voltajes peligrosos u otros riesgos.

Ranuras y aberturas • Si el equipo posee ranuras o orificios en su caja/alojamiento, es para evitar el sobrecalentamiento de componentes internos sensibles. Estas aberturas nunca se deben obstruir con otros objetos.

Batería de litio • Existe riesgo de explosión si esta batería se coloca en la posición incorrecta. Cambiar esta batería únicamente con el mismo tipo (o su equivalente) recomendado por el fabricante. Desachar las baterías usadas siguiendo las instrucciones del fabricante.

警告

电源 • 该设备只能使用产品上标明的电源。设备必须使用有地线的供电系统供电。第三条线（地线）是安全设施，不能不用或跳过。

拔掉电源 • 为安全地从设备拔掉电源，请拔掉所有设备后或桌面电源的电源线，或任何接到市电系统的电源线。

电源线保护 • 妥善布线，避免被踩踏，或重物挤压。

维护 • 所有维修必须由认证的维修人员进行。设备内部没有用户可以更换的零件。为避免出现触电危险不要自己试图打开设备盖子维修该设备。

通风孔 • 有些设备机壳上有通风槽或孔，它们是用来防止机内敏感元件过热。不要用什么东西挡住通风孔。

锂电池 • 不正确的更换电池会有爆炸的危险。必须使用与厂家推荐的相同或相近型号的电池。按照生产厂的建议处理废弃电池。



WARNING: Use of controls or adjustments other than those specified in this guide may result in hazardous radiation exposure.

The FLS 101 optical light source is a registered Class I LED and Laser Product.

WARNING: To avoid the danger of fire and electrical shock:

- Never use a voltage that is different from that for which the AC adapter is rated.
- Do not plug the unit into a power outlet that is shared by other devices.
- Never modify the power cord or excessively bend, twist, or pull it.
- Do not allow the power cord to become damaged. Do not place heavy objects on the power cord or expose it to heat.
- Never touch the AC adapter while your hands are wet.
- Should the power cord become seriously damaged (internal wiring exposed or shorted), contact the manufacturer to request servicing.

Use only the specified AC adapter. Use of another type of AC adapter can damage the instrument and create the danger of fire and electrical shock.

To avoid serious eye injury, never look directly into the optical outputs of fiber optic network equipment, test equipment, patch cords, or test reference cables. Always assume that optical outputs are on.

CAUTION: Proper care in handling should be taken when using any precision optical test equipment. Scratched or contaminated optical connectors can impact the performance of the instrument. It is important to keep the dust caps in place when the unit is not being used.

NOTE: Extron power meters and light sources contain no user serviceable parts. Except for changing batteries and cleaning optical ports, these units must be returned to Extron or authorized agents for repair and calibration.

Conventions Used in this Guide

TIP: A tip provides a suggestion to make setting up or working with the device easier.

NOTE: A note draws attention to important information.

CAUTION: A caution indicates a potential hazard to equipment or data.

WARNING: A warning warns of things or actions that might cause injury, death, or other severe consequences.

Copyright

© 2011 Extron Electronics. All rights reserved.

Trademarks

All trademarks mentioned in this guide are the properties of their respective owners.

Contents

Introduction	1	Maintenance and Troubleshooting	17
About this User Guide.....	1	Cleaning Optical Ports.....	17
About the FPM 101 and FLS 101.....	1	Cleaning FPM 101 Optical Ports.....	17
Features.....	1	Cleaning FLS 101 Optical Ports.....	18
Power Source.....	2	Repair and Calibration.....	18
Typical Applications.....	3	Battery Replacement.....	18
Accessories.....	3	Mandrels for Multimode Transmit Reference	
		Cables.....	19
		Loops for Singlemode Transmit Reference	
		Cables.....	19
Operation	4	Reference Material	20
FPM 101 Power Meter — Controls and		Specifications.....	20
Connections.....	5	Included Accessories.....	22
Power Up the FPM 101.....	6		
Wavelength/Backlight Button.....	6		
dB/dBm/ μ W Button.....	6		
Ref/Set Button.....	7		
Splash and Auto-Off Screen.....	7		
Display Readings in Test Mode.....	8		
FLS 101 Light Source — Controls and			
Connections.....	9		
FLS 101 Power.....	9		
Output Ports and Indicators.....	10		
Output Wavelength Selection.....	10		
Measuring Optical Power.....	11		
To Measure Optical Power.....	11		
Testing Fiber Optic Links.....	12		
Test the Transmit Reference Cable:.....	12		
Verify the Reference Cables:.....	13		
Insert the Link.....	14		
Using the Tone Generator.....	16		
To Quickly Identify a Fiber Optic Link.....	16		

Introduction

This introduction covers the following topics: :

- **About this User Guide**
- **About the FPM 101 and FLS 101**
- **Features**
- **Power Source**
- **Typical Applications**
- **Accessories**

About this User Guide

This user guide covers the following products:

- FPM 101 Power Meter
- FLS 101 Light Source

In this guide the term “link” refers to a fiber optic cable under test. The term “power meter” refers to the FPM 101 and the term “light source” refers to the FLS 101.

Check the Extron website at www.extron.com for additional application information.

About the FPM 101 and FLS 101

The Extron Fiber Optic Test Set includes all the equipment needed to measure optical power and loss in multimode and singlemode fiber optic equipment and fiber optic cabling. The light source includes both a multimode (MM) LED output that operates at 850 nm and 1300 nm, and a singlemode (SM) laser output that operates at 1310 nm and 1550 nm. The power meter is compatible with both multimode and singlemode fiber optic cable and features an easy-to-read LCD display for measuring optical power in dBm or watts and insertion loss in dB. The test set also includes a durable padded carrying case to organize and protect the test equipment with room for the power meter, light source, reference cables, and adapters.

Features

The Fiber Optic Test Set offers:

- A complete kit for testing power and loss in multimode and singlemode fiber optic AV systems — Includes fiber optic power meter, light source, cables, adapters, and a durable canvas tool bag.
- The fiber optic light source includes both multimode and singlemode outputs — test multimode fiber at 850 nm or 1300 nm and singlemode fiber at 1310 nm or 1550 nm.
- The fiber optic power meter accepts multimode or singlemode fiber — measure power or loss at 850 nm, 1300 nm, 1310 nm, and 1550 nm wavelengths.
- Handheld, rugged, lightweight, and battery powered.

The FPM 101 Power Meter offers:

- When used with a compatible light source such as the FLS 101, WAVE ID enables the power meter to automatically detect and set wavelengths, simplifying setup.
- Power measurements in dBm or μW ; insertion loss in dB.
- 270 Hz, 330 Hz, 1 kHz, 2 kHz tone detection.

The FLS 101 Light Source offers:

- Integrated LED and laser light source.
- WAVE ID allows a compatible power meter to automatically identify and measure a wavelength.
- Dual WAVE ID allows a compatible power meter to automatically identify and measure two wavelengths.
- CW mode for use with power meters without WAVE ID.
- 2 kHz tone for use in fiber tracing or locating.
- 50 μm and 62.5 μm mandrels included for different diameter fiber cable.
- National Institute of Standards and Technology (NIST) traceable.

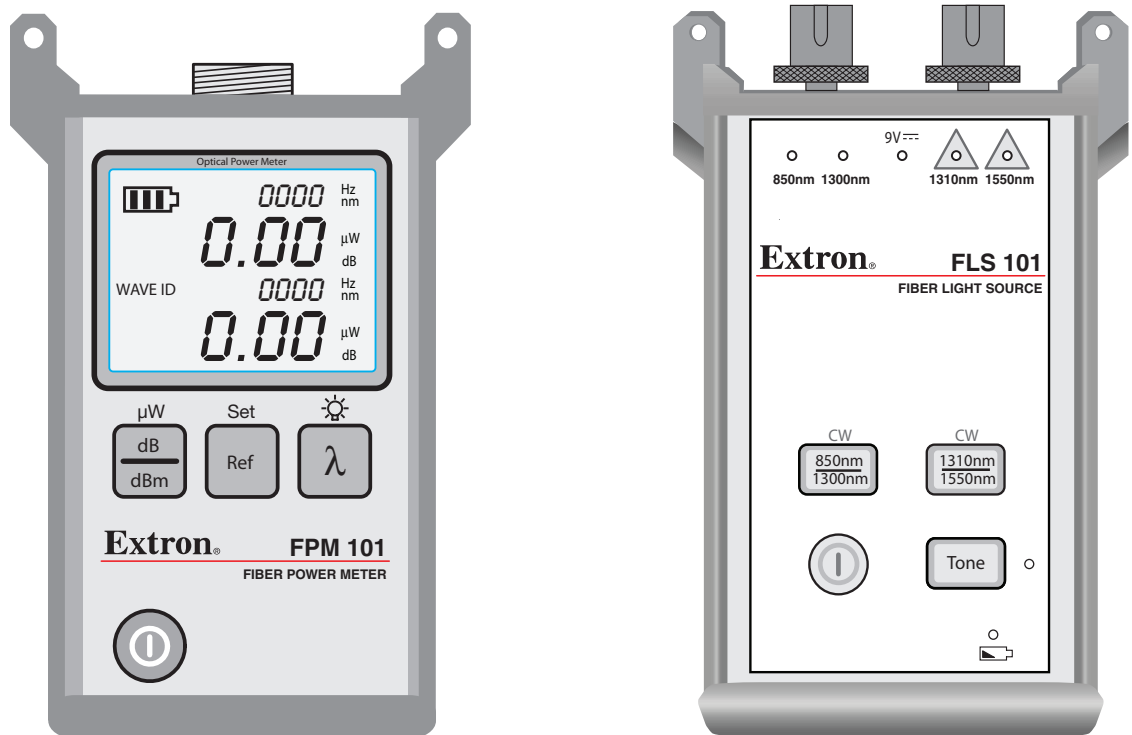

Figure 1. FPM 101 Power Meter and FLS 101 Laser Source

Power Source

The units each operate on two AA alkaline or rechargeable batteries each.

NOTE: If the battery level becomes too low, each unit turns itself off.

Typical Applications

The fiber optic test kit offers these typical applications:

FPM 101 Power Meter:

- High power model for CATV and Telco
- Enterprise/LAN for singlemode and multimode measurements
- Passive optical networks (PON) testing
- LAN/WAN multimode or singlemode networks

FLS 101 Light Source:

- Certify multimode and singlemode links per TIA/EIA standards
- Certify multimode fiber links for Gigabit Ethernet (GBE)
- Test Ethernet, Token Ring, and Fiber Distributed Data Interface (FDDI) networks
- Fiber identification before splicing

Accessories

Fiber optic test reference cables are required to connect the instruments to the fiber optic system, cable, or network under test. A test reference cable must have the same core and cladding size as the fiber under test. The connector at one end of the test reference cable must mate with the optical port on each instrument. The connector on the other end must mate with the fiber optic system under test.

LC connector adapter caps are provided for the FPM 101 and FLS 101 optical ports. One pair of singlemode and one pair of multimode reference cables with LC connectors on each end are also provided.

- NOTE:** Optical ports and connector end faces must be kept free from dirt or other contaminants to ensure accurate measurements and operation.
- For cleaning connector end faces on the FLS 101 light source, test reference cables, and in fiber frames or adapters, use optical quality cleaning fluid.
 - For cleaning the FPM/FLS 101 optical ports and adapter caps, use lint-free optical cleaning wipes with optical quality cleaning fluid and a can of filtered compressed air.

Operation

This section details the connection of fiber optic cables to the equipment for testing and measuring the power loss of a fiber optic source.

- **FPM 101 Power Meter — Controls and Connections**
- **FLS 101 Light Source — Controls and Connections**
- **Measuring Optical Power**
- **Testing Fiber Optic Links**
- **Testing Singlemode Links**
- **Using the Tone Generator**

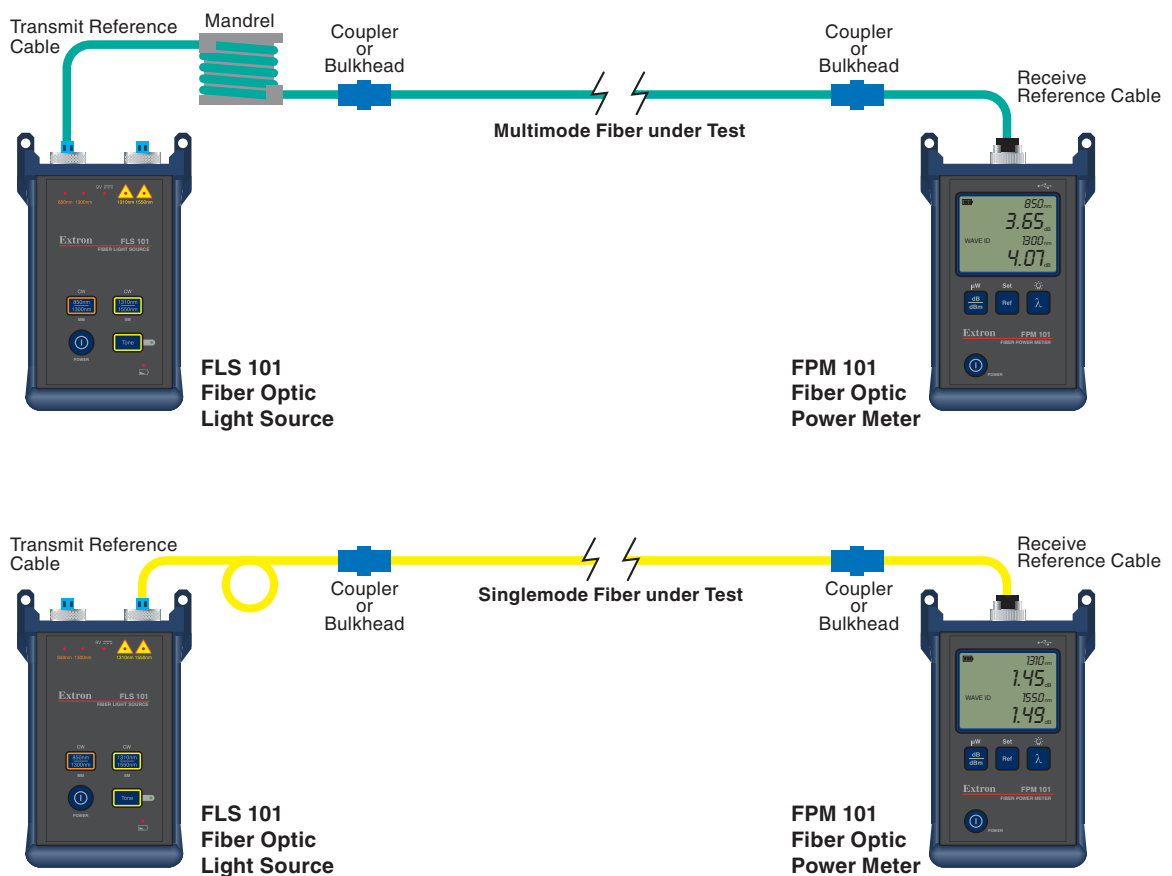

Figure 2. Typical Test Connections

FPM 101 Power Meter — Controls and Connections

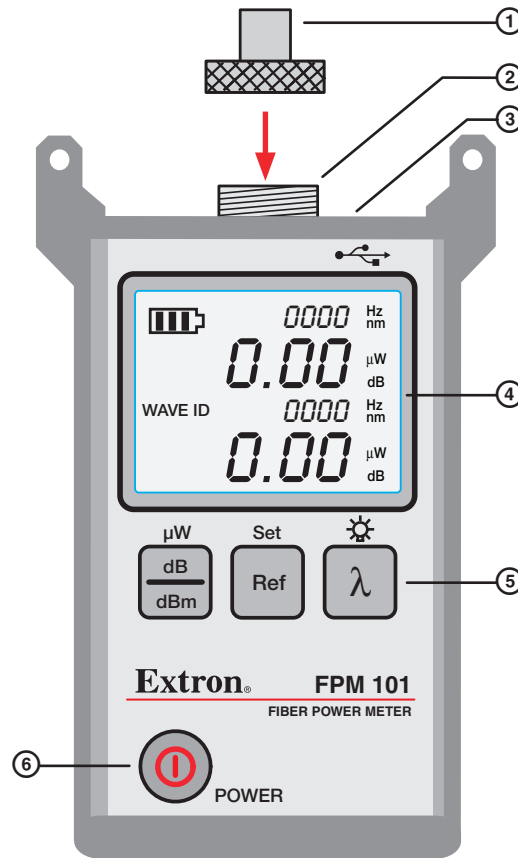



Figure 3. FPM 101 Power Meter

- ① **Adapter Cap** — Adapts the thread-on optical input to various fiber optic cable connectors. The FPM 101 includes an LC adapter cap which matches most Extron applications.
- ② **Optical input** — Accepts the thread-on adapter cap allowing you to quickly change the fiber optic connector.
- ③ **Power adapter port (located on the top panel)** — Mini-USB Type B connector for external power supply connection
- ④ **LCD Display** — Displays the various values of the selected mode including power in dBm or μW , insertion loss in dB, calibrated wavelength, tone signal in Hz, WAVE ID, references, and battery strength.
- ⑤ **Dual Function Buttons** — Three buttons, each with primary and secondary functions, to select power measurement type, (λ), set the reference level, (Ref), and manually select the measurement wavelength, (dB/dBm). A press and release activates the function designated by the button label. Press and hold the button to activate the secondary function indicated by the text above the button.
- ⑥ **Power Button** — When the meter is off, press and hold for a short time to toggle it on. When the meter is on, press to turn off, or press and hold to toggle the auto-off feature on or off (see **“Power Up the FPM 101”** on page 6).

Power Up the FPM 101

The power button provides two functions:

- Press and hold the power button, , for a short time until the display lights up to turn the meter on. When the meter is on, press and release the button to turn the FPM 101 off.
- Press and hold the button when the meter is on to disable/enable the auto-off feature. Auto-off powers down the unit after five minutes of inactivity.
 - If the auto-off feature is enabled, (default), press and hold the power button until HELD pON appears on the display.
 - If the auto-off feature is disabled, press and hold the power button until HELD AOFF appears on the display.

Wavelength/Backlight Button

The wavelength/backlight button, , provides two functions:

- Press and hold to toggle the backlight on or off.
- To manually select a wavelength, press and release to cycle through the wavelengths as shown.

850 nm >1300 nm >1310 nm >1490 nm >1550 nm >850 nm ...

NOTE: When using the FLS 101 set to a WAVE ID output, the FPM 101 automatically switches to the WAVE ID wavelength. The WAVE ID indicator appears on the display and the wavelength is displayed in the calibrated wavelength indicator field.

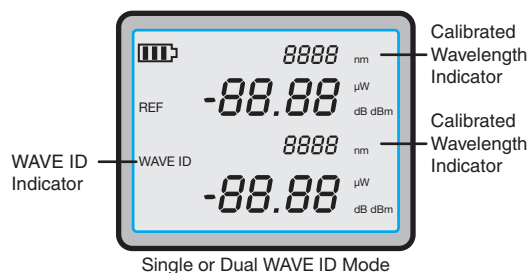

dB/dBm/ μ W Button

The dB/dBm/ μ W button, , provides two functions:

- Press and release to toggle display readings between insertion loss (dB) or power (dBm).
- Press and hold to view power in microwatts (μ W).

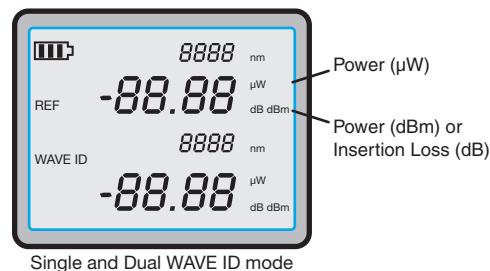

Ref/Set Button

The Ref/Set button, , provides two functions:

- Press and hold to store the power level values for a set of reference cables, (Set),
- Press and release to display previously stored references, (Ref).

Test Mode: To Set a Reference

1. Refer to the sections describing connection of reference cables (see **“Testing Fiber Optic Links”** on page 12).
2. Set the FPM 101 to the desired measurement mode (dBm or uW) (see **“dB/dBm/μW Button”** in the previous section).
3. To store the currently measured level or multiple levels (in dual WAVE ID mode) as the new reference level, press and hold the Ref/Set button until HELDSET is displayed.
4. Once the new reference is set, the FPM 101 switches to insertion loss (dB) mode.

NOTE: When setting references from dual WAVE ID sources, additional time is required for the power meter to identify and measure both wavelengths. Allow several seconds before pressing the Ref/Set button in step 3.

Test Mode: To View the Reference

1. Press the Ref/Set button to display the stored reference wavelength and power level for the currently selected wavelength or detected WAVE ID wavelengths. The reference indicator (Ⓢ, below) lights, and the reference values are displayed briefly (several seconds) as follows:



Single and Dual WAVE ID mode

Continuous Wave (CW) mode — The reference wavelength and power level are displayed at ②

Single WAVE ID mode — The reference wavelength and power level are displayed at ②

Dual WAVE ID mode — The first reference wavelength and power level are displayed at ②, and the second at ③.

Splash and Auto-Off Screen

Splash (Version) Screen — During power up, the FPM 101 software version is shown on the top line, (Ⓢ). The FPM 101 type and detector type are shown on the next line (Ⓢ). The splash screen is replaced by the normal display after about two seconds.

Auto-off Screen — When the unit is about to power down due to inactivity, the display shows OFF for a brief time on line ⑤, then counts down the number of seconds until power is shut off.

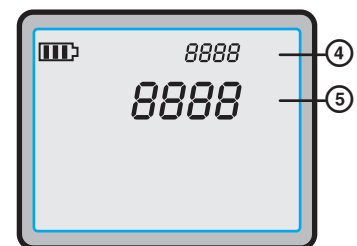

Display Readings in Test Mode

The following table lists descriptions for the LCD display readouts in various modes of operation.

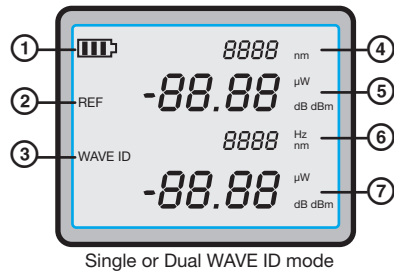

Figure 4. FPM 101 Display

Item	Field	Description
①	Battery status indicator	Displays the approximate remaining battery life. Three bars indicate the charge level. When the battery indicator flashes, the batteries should be changed immediately.
②	REF indicator	Press the Ref/Set button to toggle through stored reference values. The reference values for the currently selected wavelengths are briefly displayed in the following order: CW mode: The reference value is displayed in field ⑤. Single WAVE ID mode: The reference value is displayed in field ⑤. Dual WAVE ID mode: The reference values are displayed in fields ⑤ and ⑦.
③	WAVE ID indicator	Lights when a wavelength has been identified using the WAVE ID feature with a compatible light source.
④	Wavelength	CW mode: Displays the currently selected wavelength. Single WAVE ID mode: Displays the detected WAVE ID wavelength. Dual WAVE ID mode: Displays the first detected WAVE ID wavelength.
⑤	Power	Displays measured power (dBm or μ W), or insertion loss (dB) at the wavelength displayed in field ④. If power or loss is too high or too low for accurate measurement, this field displays HI or LO.
⑥	Tone / Wavelength	CW mode: Displays detected tone modulation frequency. Dual WAVE ID mode: Displays the second detected WAVE ID wavelength.
⑦	Power (Dual WAVE ID mode only)	Displays measured power (dBm or μ W), or insertion loss (dB) at the wavelength displayed in field ⑥. If power or loss is too high or too low for accurate measurement, this field displays HI or LO.

FLS 101 Light Source — Controls and Connections

The FLS 101 light source can test fiber optic links by generating the proper wavelength light for the link under test. The light source can generate multimode 850 nm and 1300 nm wavelengths, or singlemode 1310 nm and 1550 nm wavelengths. For each mode, (SM or MM), the two wavelengths can be generated one at a time or alternating between the two.

NOTE: The light source can only emit light from one output port at a time.

In WAVE ID mode, the light source emits a signal with the light allowing the FPM 101 fiber power meter to automatically determine the wavelength.

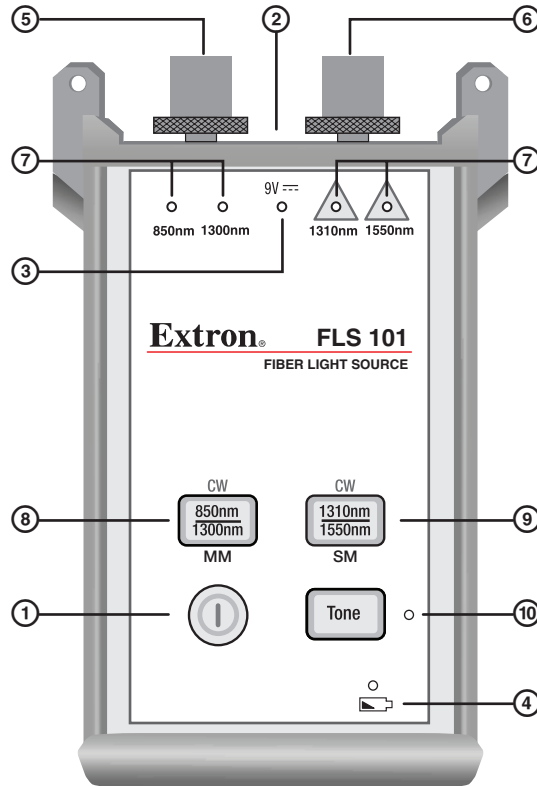

Figure 5. FLS 101 Light Source

FLS 101 Power

① **Power button** — Press and hold until all indicators light up to turn the FLS 101 on. The FLS 101 initially turns on in its default condition: 850/1300 nm, dual mode sending Wavelength ID (WAVE ID). After that, all settings made before the light source is turned off are retained. Press and hold again to turn the FLS 101 off.

② **Power port (located on the top panel)** — Connector for the AC power adapter.

③ **External power indicator** — Lights when the correct AC power adapter is connected.

NOTE: Whether the FLS 101 is on or not, the indicator LED stays lit as long as the adapter is connected and powered.

④ **Low battery indicator** — Lights when a low battery condition exists requiring battery replacement.

Output Ports and Indicators

The optical output ports require adapter caps for connection to fiber optic links and reference cables. The FLS 101 includes two LC adapter caps.

- ⑤ **MM output port** — LED source multimode optical output.
- ⑥ **SM output port** — Laser source singlemode optical output.
- ⑦ **Active output indicators (lit when the corresponding output port is On)** — The active output indicators light as follows:

Test Mode	Active Output Indicator Status
WAVE ID, dual wave	Corresponding wavelength indicator is lit, alternating between the two active wavelengths
WAVE ID, single wave	Selected wavelength indicator is lit
CW or tone	Selected wavelength indicator is blinking

Output Wavelength Selection

- ⑧ **850/1300/CW button** — Multimode wavelength select button provides functions as follows:

WAVE ID Mode

Press and release the button to cycle through output wavelengths in the following order:

Dual 850/1300 nm > 850 nm > 1300 nm > Dual 850/1300 nm > ...

The corresponding MM active output port indicators light.

CW Mode

- Press and hold the button to switch to the CW mode. Press and hold the button again to select a single wavelength in the following order:
850 nm > 1300 nm > 850 nm > ... Release the button when the desired wavelength port indicator turns on. The selected MM active output port indicator blinks.
- Press and release the button to return to the WAVE ID mode.

- ⑨ **1310/1550/CW button** — Singlemode wavelength select button provides functions as follows:

WAVE ID Mode

Press and release the button to cycle through output wavelengths in the following order:

Dual 1310/1550 nm > 1310 nm > 1550 nm > Dual 1310/1550 nm > ...

CW Mode

- Press and hold the button to switch to the CW mode at the current wavelength. Press and hold the button again to select a single wavelength in the following order:
1310 nm > 1550 nm > 1310 nm > ... Release the button when the desired wavelength port indicator turns on. The selected SM active output port indicator blinks.
- Press and release the button to return to the WAVE ID mode.

- ⑩ **Tone button and Indicator** —

Tone button (1550 nm, SM only) — Press the tone button to toggle the 2 kHz tone function on/off. When the tone mode is disabled, the unit returns to the WAVE ID mode at the currently selected wavelength.

NOTE: When the tone feature is active, WAVE ID is disabled and the output level is reduced by 3 dB.

Tone indicator — The Tone indicator is lit when the FLS 101 is transmitting in tone mode.

Measuring Optical Power

CAUTION: It is important to keep all optical connections and surfaces free from dirt, oils, or other contaminants to ensure proper operation. Always clean all test reference cables before conducting the test procedures outlined in this guide. See [“Cleaning Optical Ports”](#) on page 17 for details.

To Measure Optical Power

1. Turn on the FPM 101 power meter by pressing the power button (ⓘ).
2. Select the appropriate fiber optic reference cable. The fiber type of this cable must be the same as the fiber type normally connected to the equipment output being measured.

NOTE: Always verify that reference cable loss is not excessive (< 0.5 dB), before measuring the power output of fiber optic equipment (see [“Testing Fiber Optic Links”](#) on page 12).

3. Select the adapter cap matching the reference cable connector and type.
4. Connect one end of the reference cable to the adapter cap and the other end to the optical output to be measured.
5. Press the wavelength button (Ⓟ) to select the calibrated wavelength matching the nominal wavelength of the source under measurement.
6. If the power meter is presently measuring insertion loss in dB, press the dB/dBm button (Ⓞ) to display power in dBm, or press and hold it to display power in μ W.

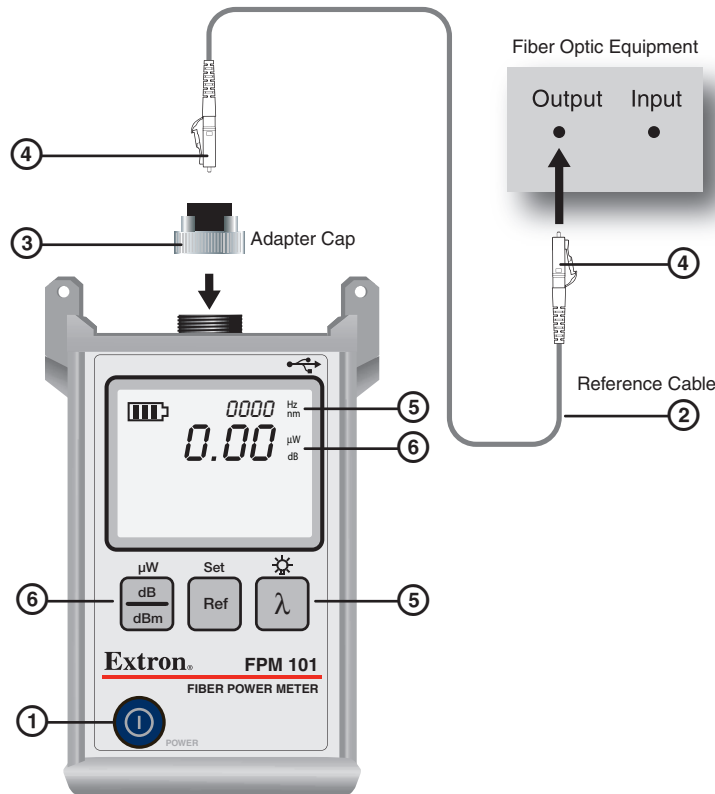

Figure 6. Power Measurement Connections

Testing Fiber Optic Links

Multimode or singlemode links are easily measured using the FPM 101 power meter and FLS 101 light source. Two reference cables, transmit and receive, are required. Before an unknown fiber link can be measured, the insertion loss of the two reference cables must first be verified to be less than 0.75 dB.

Test the Transmit Reference Cable:

1. Turn on the FPM 101 power meter and FLS 101 light source. Allow the light source to stabilize for a minimum of two minutes prior to taking measurements.
2. Set the desired measurement wavelength on the FLS 101 light source, (see **“Output Wavelength Selection”** on page 10).
 - a. When using the WAVE ID feature, the FPM 101 power meter reads the wavelength automatically.
 - b. If not using WAVE ID, set the FPM 101 to the same wavelength as the FLS 101, (see **“Wavelength/Backlight Button”** on page 6).
3. Select and prepare the transmit reference cable. The fiber type of the reference cable must match the fiber type of the link to be tested.
 - a. **MM:** Wrap and secure the reference cable five times around the included mandrel.
 - b. **SM (TIA testing only):** Form and secure a 1.2 inch (30 mm) diameter loop in the reference cable.

NOTE: Clean both ends of the transmit reference cable before proceeding.

4. Connect the transmit reference cable to the FLS 101 output port (MM or SM).
5. Mount an adapter cap on the power meter. The adapter cap must match the free connector on the transmit reference cable.
6. Connect the free end of the reference cable to the FPM 101. If necessary, press the dB/dBm button to display optical power in dBm, (see **“dB/dBm/ μ W Button”** on page 6).

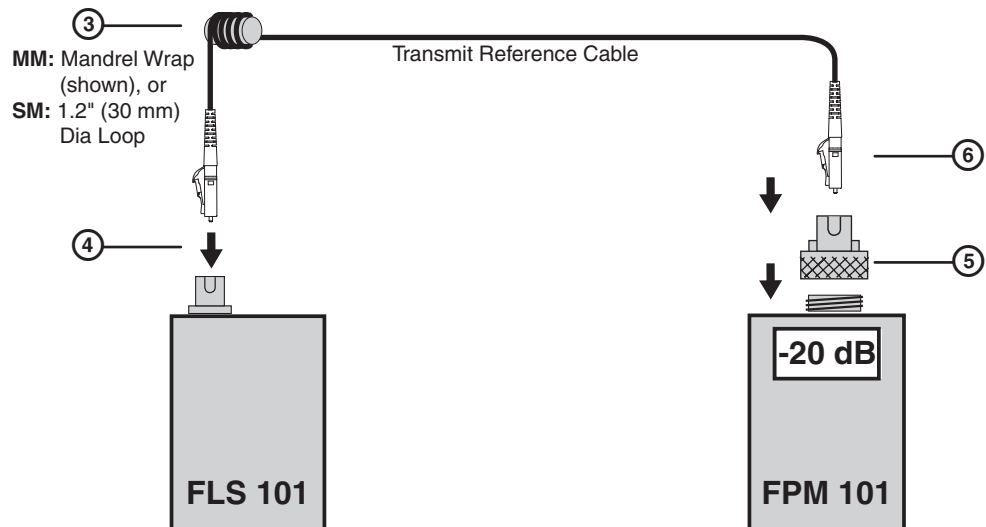

Figure 7. Transmit Reference Cable Connection

7. The normal range is -20 dBm for multimode cables, 0 dBm for singlemode, (± 1 dB).

NOTE: Output power for multimode cables is approximately 3 dB less when a 50 μ m mandrel wrapped reference cable is used, or if the tone feature is activated.

If the measured output power is outside the normal range, or the display reads HI or LO:

- Clean all fiber connections and repeat step 6, or
 - If cleaning fails, replace the transmit reference cable, then repeat steps 3 through 7.
8. To store the FPM 101 reference level with the current wavelength, press and hold the Ref/Set button until HELD SET is displayed. See “Ref/Set Button” on page 7. The current levels are now the new reference levels. Once the new reference is stored, the FPM 101 automatically switches to the insertion loss measurement mode and the display reads 0 dB, ± 0.05 dB.

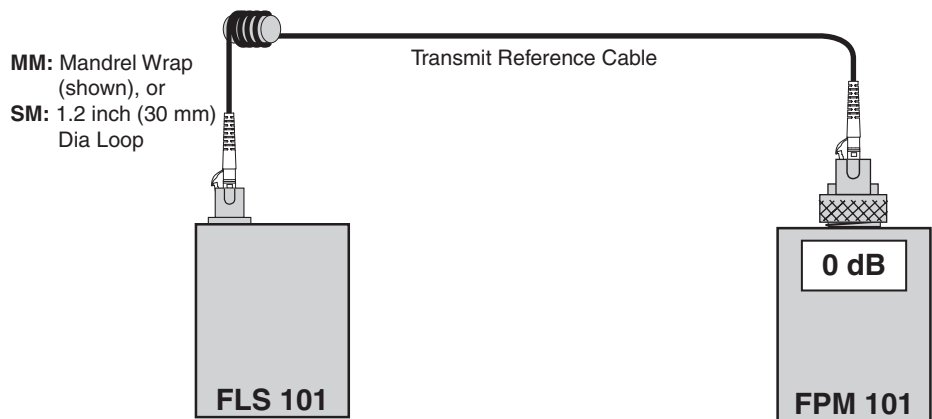

Figure 8. Transmit Reference Cable Connection After Reference Set

NOTE: To display the stored reference power levels for each wavelength, press the Ref/Set button.

When setting a reference level from multiple WAVE ID sources, allow a few seconds for the wavelengths to be identified and measured before storing the references.

Verify the Reference Cables:

9. Disconnect the transmit reference cable from the FPM 101.
Do not disturb the transmit reference cable connection on the FLS 101.
10. If necessary, change the FPM 101 adapter cap to match the connector of the receive reference cable that will be connected to the power meter.
Clean both ends of the receive reference cable.

11. Connect the receive reference cable to the FPM 101.
12. Connect the free ends of the transmit and receive reference cables together using an appropriate coupler, or use a nearby bulkhead connector.

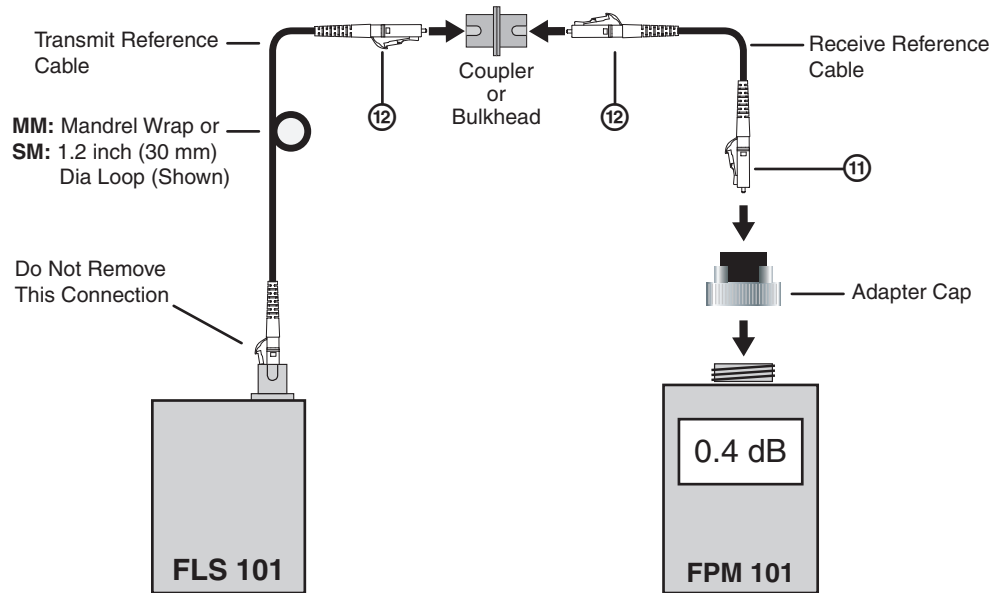

Figure 9. Connect the Receive Reference Cable

13. Verify the insertion loss of the reference cable pair is less than 0.75 dB, the maximum allowed by the TIA (Extron recommends 0.4–0.5 dB).

If the insertion loss (dB) is not within these values:

- Disconnect the transmit and receive cables at the coupler (or bulkhead). Clean the free ends of both cables and both sides of the coupler (bulkhead), then repeat step 11 through 13.
- If the insertion loss is still not acceptable, replace both test reference cables and begin again with step 1 on page 12.

Insert the Link

1. When the insertion loss is acceptable, (<0.75 dB), disconnect both the transmit and receive reference cables from the coupler or bulkhead.

NOTE: Do not disturb the reference cable connections at the light source or the power meter.

- Insert the link to be tested by connecting it to the free ends of the transmit and receive reference cables using appropriate couplings, or connect the reference cables to the bulkhead connections of the link as shown in figure 10 below.

NOTE: Clean reference cable and link ends prior to each test.

- Observe the displayed values. The link cable insertion loss is displayed in dB.

NOTE: If either the light source or power meter has shut off, turn it back on and allow to stabilize for a minimum of two minutes.

The two examples in figure 10 below show a multimode and singlemode fiber link being tested using dual WAVE ID. The insertion loss is displayed in dB.

In the multimode example, the FLS 101 is transmitting both 850 nm and 1300 nm wavelengths. The FPM 101 has automatically detected the wavelengths using WAVE ID and is reading a 3.65 dB loss for the 850 nm and 4.07 dB for 1300 nm.

The singlemode example, also using dual WAVE ID, is reading a 1.45 dB loss for the 1310 nm wavelength and 1.49 dB for 1550 nm.

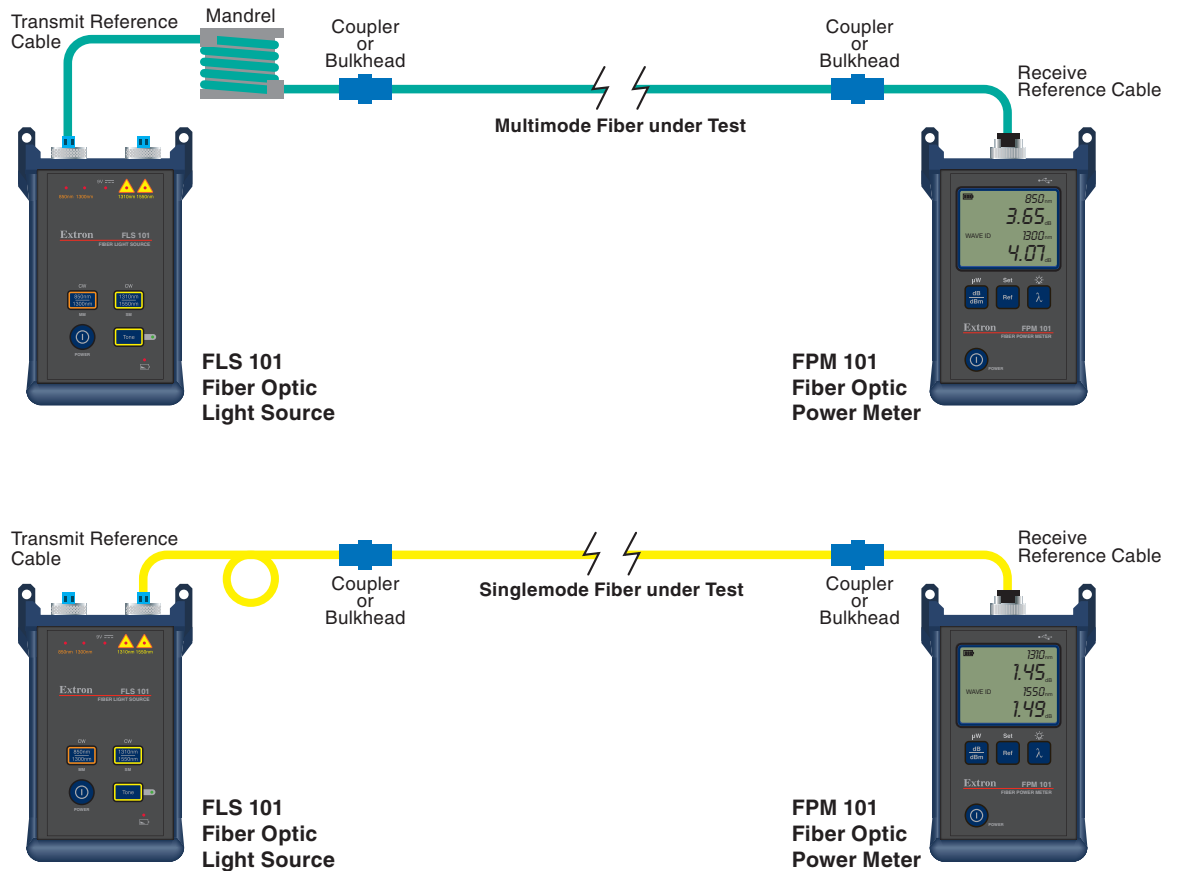

Figure 10. Connections to Measure Link Insertion Loss

Using the Tone Generator

The tone generator is used for fiber identification when an installer is faced with multiple unmarked links and the cable ends are not readily accessible by a single technician or are far removed from one another. The tone is inserted by the light source at one end of the link and identified at the other using the tone feature of the FPM 101.

In new installations, the link ends can be identified with the FLS 101 and FPM 101 using the WAVE ID feature and simply looking for the active link among the inactive links. However, in larger bundles that may have links carrying live data traffic, the tone generator in the FLS 101 can be used to identify spare links. The FPM 101 can differentiate between live traffic on fibers and the 2 kHz test tone generated by the FLS 101 to ensure a live fiber is not cut or disconnected causing a disruption of critical services.

To Quickly Identify a Fiber Optic Link

1. Connect the light source to one end of the link to be identified. Use the appropriate reference cable and coupler.
2. Select the 1550 nm wavelength using the SM button, then turn on the 2 kHz tone by pressing the tone button. The tone indicator LED lights.
3. On the other end of the link, if the bulkhead is not accessible, unplug the cables one at a time and connect them into the receive reference cable using a coupler. The cable that causes the 2000 Hz display to light is the desired cable.

NOTE: Cables with live data traffic are identified by their wavelength and signal strength but they do not light the tone display.

Identifying wavelengths is not instantaneous. Always wait a few moments for the FPM 101 to identify the signal.

Mark the cable ends for reference.
Clean the connectors and couplers often.

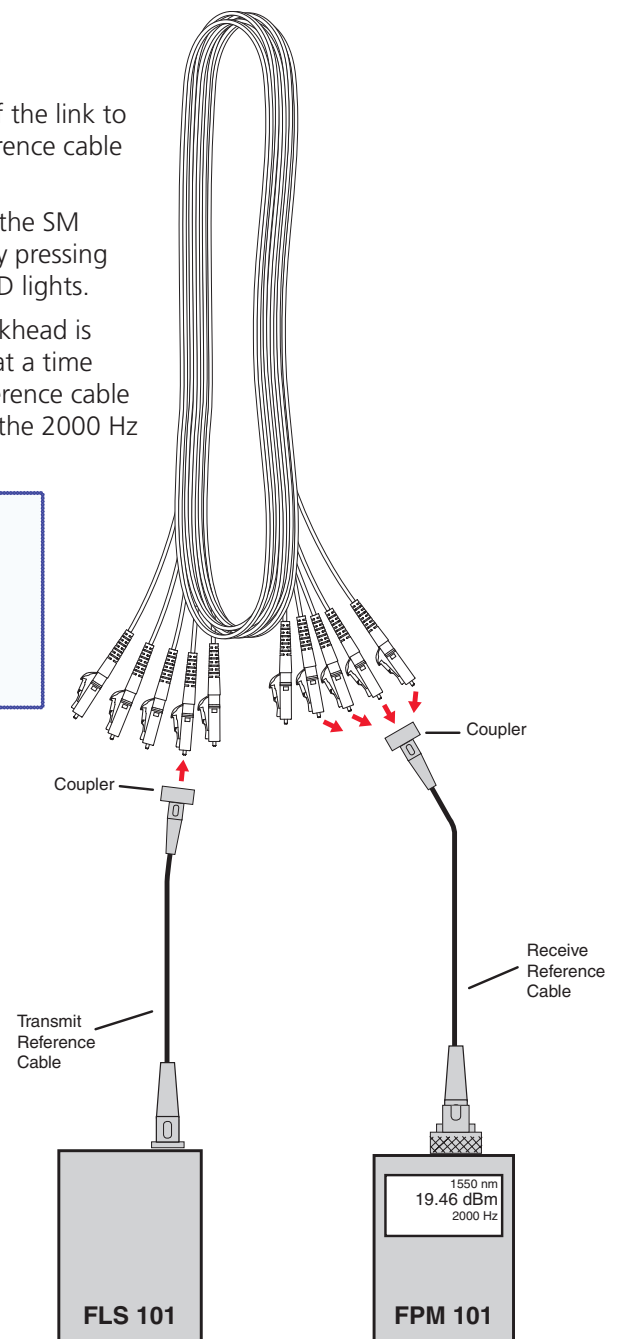

Figure 14. Tone Identification Connections

Maintenance and Troubleshooting

This section provides preventative maintenance and troubleshooting suggestions.

- **Cleaning Optical Ports**
- **Repair and Calibration**
- **Battery Replacement**
- **Mandrels for Multimode Transmit Reference Cables**
- **Loops for Singlemode Single Reference Cables**

Cleaning Optical Ports

CAUTION: Before conducting the following procedures be certain the instruments are turned **Off**. Disconnect the external supply from the FLS 101.

Optical ports must be kept free from dirt or other contaminants to ensure accurate measurements and operation. Always clean reference cables before conducting the test procedures outlined in this guide. It is important to keep dust caps in place when instruments are not being used.

For cleaning connector end faces on the FLS 101 light sources, test reference cables, and in fiber frames or adapters, use optical quality cleaning fluid and molded cleaning tips.

For cleaning the FPM 101 optical ports and adapter caps, use lint-free optical cleaning wipes and optical quality cleaning fluid such as IPA -Reagent Grade Isopropyl Alcohol 99% or better) and a can of filtered compressed air.

Cleaning FPM 101 Optical Ports

1. Unscrew the adapter cap from the adapter cap mount.
2. Use lint-free optical cleaning wipes and optical quality cleaning fluid and dampen a portion of the wipe with the cleaning fluid.

NOTE: If using isopropyl alcohol (IPA), be sure to use 99% pure IPA that has not been contaminated.

3. Gently wipe the exposed FPM 101 port starting with the wet section of the wipe and pulling it to the dry section.

NOTE: Starting with wet cleaning and finishing with dry improves cleaning action, reduces static buildup, and leaves the end-face dry.

4. Using a can of filtered compressed air (held vertically), blow out any contaminants from the adapter cap.
5. Once the cleaning is complete, replace the adapter cap.

Cleaning FLS 101 Optical Ports

1. Rotate the adapter base counterclockwise approximately four times.
2. Pull the adapter directly out and away from the adapter mount.
3. Dampen an optical wipe with alcohol and gently wipe the exposed ferrule.

NOTE: Be certain to use 99% IPA that has not been contaminated.

4. Dry the ferrule using a new optical wipe.
5. Using a can of filtered compressed air (held vertically), blow out any remaining contaminants from the adapter.
6. Replace the adapter making sure the alignment pin on the adapter aligns with the mating hole on the base.

Repair and Calibration

Repair of the test equipment in the field is not recommended.

Calibration of the test equipment is recommended every 12 months.

Contact your Extron representative for calibration or repair of the test equipment.

Battery Replacement

1. Remove the protective rubber boot from the instrument.
2. Remove the battery compartment cover located on the back of the instrument.
3. Remove the discharged batteries.
4. Observe the proper polarity and place new batteries in the compartment.
5. Replace the battery compartment cover and rubber boot.

Mandrels for Multimode Transmit Reference Cables

When testing multimode links using an overfilled LED source, always wrap the transmit reference cable five (5) times around the proper diameter mandrel. This is specified by TIA/EIA-568-B and improves insertion loss measurement repeatability and accuracy. Do **NOT** use mandrels on multimode **receive** reference cables or singlemode reference cables.

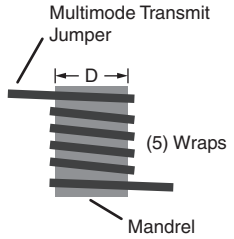
Available mandrels for test reference cables with 3 mm jackets		Diameter (D) for other jacket diameters (in mm)	
Fiber Type	Part Number		
62.5 μm	Contact Extron	D = 20 mm minus jacket diameter	
50 μm	Contact Extron	D = 25 mm minus jacket diameter	
Kit with both mandrels	Contact Extron		

Loops for Singlemode Transmit Reference Cables

For TIA testing of singlemode links, the transmit reference cable must have a 1.2 inch (30 mm) loop secured by tape, hook and loop fasteners, or other means. Do not pull the fastener too tight.

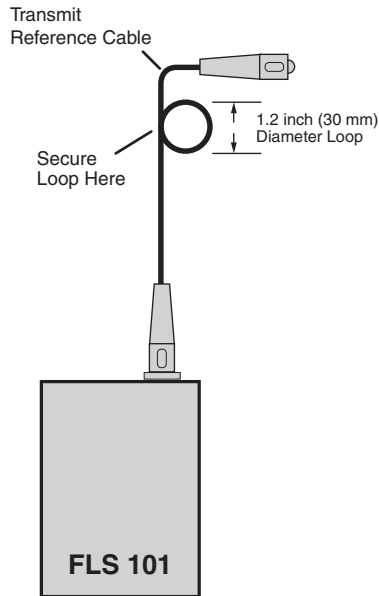

Reference Material

This section provides technical specifications, included and replacement part numbers, and optional accessories.

- **Specifications**
- **Included Accessories**

Specifications

NOTE: These devices are class 1 laser products. They meet the safety regulations of IEC-60825, FDA 21 CFR 1040.10, and FDA 21 CFR 1040.11.

Optical specifications — FLS 101 fiber optic output

Number/type	
Singlemode	1 laser emitter
Multimode.....	1 LED emitter
Connectors	2 connectors with LC, SC FC, and ST adapters
Wavelengths	
Singlemode	1310 nm \pm 20 nm, 1550 nm \pm 20 nm
Multimode.....	850 nm \pm 30 nm, 1310 nm -10/+50 nm
Spectral width	
Singlemode	5 nm (max.) at 1310 nm and at 1550 nm
Multimode.....	40 nm (typical) at 850 nm 120 nm (typical) at 1310 nm
Transmission power	
Singlemode	0 dBm, 9 μ m
Multimode.....	-20 dBm, 62.5 μ m

NOTE: Power will be 3 dB lower if a 50 μ m mandrel-wrapped jumper is used instead of a 62.5 μ m mandrel-wrapped jumper.

Stability	
Singlemode	\pm 0.05 dB over 1 hour after 15 minute warmup \pm 0.1 dB over 8 hours after 15 minute warmup
Multimode.....	\pm 0.1 dB over 8 hours after 5 minute warmup

Optical specifications— FPM 101

Wavelengths	850 nm, 1300 nm, 1310 nm, 1490 nm, 1550 nm; calibrated
Detector type	Germanium (Ge)
Units of measurement	dB, dBm, μ W

Testing ranges	
Measurement	-60 to +6 dBm
Tone detection	At 850 nm: -45 to +6 dBm At all other wavelengths: -50 to +6 dBm
Wavelength identification	At 850 nm: -45 to +6 dBm At all other wavelengths: -50 to +6 dBm
Resolution	0.01 dB
Accuracy	±0.25 dB at -10 dBm

General

Power	
FLS 101	Internal batteries or External, supplied by optional AC adapter Input: 100-240 VAC, 50-60 Hz Output: 9 VDC, 1.5 A, 13 watts
FPM 101	Internal batteries or External Supplied via USB port
Power consumption	
FLS 101	LED transmission: 1.8 watts, 3 VDC Laser transmission: 1.5 watts, 3 VDC
FPM 101	2.7 watts, 3 VDC with backlight on
Batteries	
Number/type	2 AA batteries (1.5 V alkaline or 1.2 V rechargeable)
Operating time (nominal)	
FLS 101	Multimode operation: 20 hours Singlemode operation: 72 hours
FPM 101	300 hours
Temperature/humidity	Storage: -22 to +140 °F (-30 to +60 °C) / 10% to 90%, noncondensing Operating: +14 to +122 °F (-10 to +50 °C) / 10% to 90%, noncondensing
Cooling	Convection, no vents
Thermal dissipation	1.1 BTU/hr
Mounting	No
Enclosure type	Plastic
Enclosure dimensions	4.5" H x 2.6" W x 1.0" D (11.5 cm H x 6.7 cm W x 2.5 cm D) (Excluding the rubber boot, connectors.) 5.5" H x 3.6" W x 1.5" D (14.0 cm H x 9.1 cm W x 3.8 cm D) (Including including rubber boot and connectors.)
Product weight	
FLS 101	0.7 lb (0.3 kg)
FPM 101	0.6 lb (0.3 kg)
Shipping weight	2 lbs (1 kg)
Vibration	ISTA 1A in carton (International Safe Transit Association)
Regulatory compliance	
Safety	EN 61010-1
EMI/EMC	EN 61000-4, EN 61326-1
Warranty	3 years parts and labor, excluding batteries

NOTE: All nominal levels are at ±10%.

NOTE: Specifications are subject to change without notice.

Included Accessories

Description	Part Number
FPM 101 power meter	
FLS 101 light source	
Batteries (4 AA)	
Soft Pouch	
LC singlemode reference cable (x2)	
LC multimode reference cable (x2)	
Light Source LC Adapter (x2)	
Power Meter LC Adapter Cap	
<i>FPM/FLS 101 Setup Guide</i>	

Extron® Warranty

Extron Electronics warrants this product against defects in materials and workmanship for a period of three years from the date of purchase. In the event of malfunction during the warranty period attributable directly to faulty workmanship and/or materials, Extron Electronics will, at its option, repair or replace said products or components, to whatever extent it shall deem necessary to restore said product to proper operating condition, provided that it is returned within the warranty period, with proof of purchase and description of malfunction to:

USA, Canada, South America, and Central America:

Extron Electronics
1001 East Ball Road
Anaheim, CA 92805
U.S.A.

Japan:

Extron Electronics, Japan
Kyodo Building, 16 Ichibancho
Chiyoda-ku, Tokyo 102-0082
Japan

Europe, Africa, and the Middle East:

Extron Europe
Hanzeboulevard 10
3825 PH Amersfoort
The Netherlands

China:

Extron China
686 Ronghua Road
Songjiang District
Shanghai 201611
China

Asia:

Extron Asia
135 Joo Seng Road, #04-01
PM Industrial Bldg.
Singapore 368363
Singapore

Middle East:

Extron Middle East
Dubai Airport Free Zone
F12, PO Box 293666
United Arab Emirates, Dubai

This Limited Warranty does not apply if the fault has been caused by misuse, improper handling care, electrical or mechanical abuse, abnormal operating conditions, or modifications were made to the product that were not authorized by Extron.

NOTE: If a product is defective, please call Extron and ask for an Application Engineer to receive an RA (Return Authorization) number. This will begin the repair process.

USA: (714) 491-1500
Asia: 65.6383.4400

Europe: 31.33.453.4040
Japan: 81.3.3511.7655

Units must be returned insured, with shipping charges prepaid. If not insured, you assume the risk of loss or damage during shipment. Returned units must include the serial number and a description of the problem, as well as the name of the person to contact in case there are any questions.

Extron Electronics makes no further warranties either expressed or implied with respect to the product and its quality, performance, merchantability, or fitness for any particular use. In no event will Extron Electronics be liable for direct, indirect, or consequential damages resulting from any defect in this product even if Extron Electronics has been advised of such damage.

Please note that laws vary from state to state and country to country, and that some provisions of this warranty may not apply to you.

Extron USA - West Headquarters	Extron USA - East	Extron Europe	Extron Asia	Extron Japan	Extron China	Extron Middle East
+800.633.9876 Inside USA/Canada Only	+800.633.9876 Inside USA/Canada Only	+800.3987.6673 Inside Europe Only	+800.7339.8766 Inside Asia Only	+81.3.3511.7655 +81.3.3511.7656 FAX	+400.883.1568 Inside China Only	+971.4.2991800 +971.4.2991880 FAX
+1.714.491.1500 +1.714.491.1517 FAX	+1.919.863.1794 +1.919.863.1797 FAX	+31.33.453.4040 +31.33.453.4050 FAX	+65.6383.4400 +65.6383.4664 FAX		+86.21.3760.1568 +86.21.3760.1566 FAX	